

Please note:
When the distance is 1400mm, you have to mount spacer brace on the wall.

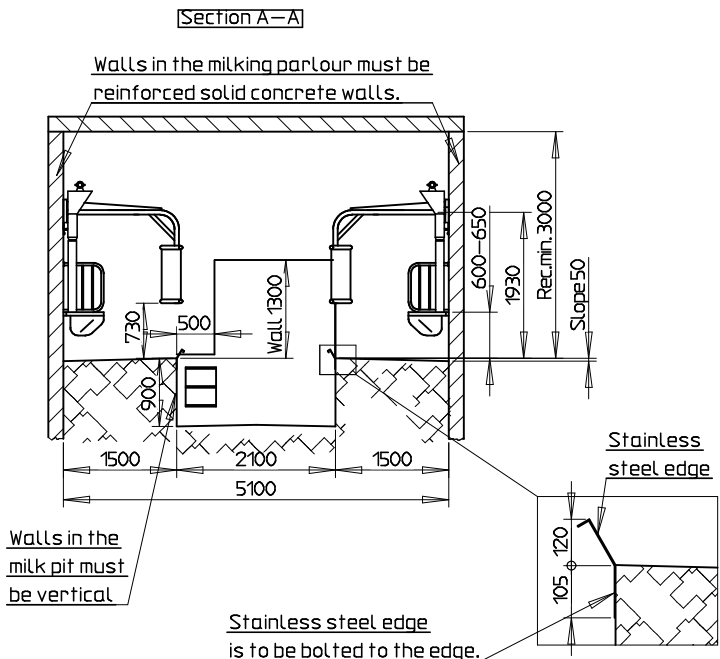

Please note!
Ventilation:
During building up there must be provided the necessary ventilation to prevent condensed water in the milking parlour.

The walls of the milking Parlour, on which you mount the stall construction must be flat. No posts, rafters etc. are allowed as they might obstruct to the cows.

All measures in mm

STRANGKO A/S		Tolerance:	Overload:	Målestok: 1:050,0	Vægt:
HORNE, DK-6800 VARDE				Materiale:	
TEL. +4575260211				Dimension:	
				Beskrivelse:	
				Milking Parlour 2x7 Extra with feedtrough	
				Tegningnummer:	Side:
				02 207 019 01	1
A	Div.ændr.	28.04.04	jl		
Rev.	Rettelser	Date	Navn	Original:	Erh. f.: